



VKD DN 10÷50
PVC-U

DUAL BLOCK® 2-way ball valve

VKD DN 10÷50

FIP has developed a VKD DUAL BLOCK® ball valve to introduce a high reference standard in thermoplastic valve design. VKD is a True Union ball valve that meets the most stringent needs required by industrial applications.

DUAL BLOCK® 2-WAY BALL VALVE

- Connection system for solvent weld, threaded and flanged joints
- Patented **SEAT STOP®** ball carrier system that lets you micro-adjust ball seats and minimise the axial force effect.
- Easy radial dismounting allowing quick replacement of O-rings and ball seats without any need for tools
- **PN16 True Union valve body** made for rigid PVC-U injection moulding equipped with built-in bores for actuation. ISO 9393 compliant test requirements
- Option of dismounting downstream pipes with the valve in the closed position
- Floating **full bore ball** with high surface finish
- **Integrated bracket** for valve anchoring
- Ball seat carriers can be adjusted using the **Easytorque adjustment kit**



Technical specifications	
Construction	2-way True Union ball valve with locked carrier and union nuts.
Size range	DN 10 ÷ 50
Nominal pressure	PN 16 with water at 20 °C
Temperature range	0 °C ÷ 60 °C
Coupling standards	<p>Solvent welding: EN ISO 1452, EN ISO 15493, BS 4346-1, DIN 8063, NF T54-028, ASTM D 2467, JIS K 6743. Pipe coupling as per EN ISO 1452, EN ISO 15493, DIN 8062, NF T54-016, ASTM D 1785, JIS K 6741.</p> <p>Thread: ISO 228-1, DIN 2999, ASTM D 2464, JIS B 0203.</p> <p>Flanging system: ISO 7005-1, EN ISO 1452, EN ISO 15493, EN 558-1, DIN 2501, ANSI B.16.5 cl. 150, JIS B 2220.</p>
Reference standards	<p>Construction criteria: EN ISO 16135, EN ISO 1452, EN ISO 15493</p> <p>Test methods and requirements: ISO 9393</p> <p>Installation criteria: DVS 2204, DVS 2221, UNI 11242</p> <p>Actuator couplings: ISO 5211</p>
Valve material	PVC-U
Seal material	EPDM, FPM (standard size O-Ring); PTFE (ball seats)
Control options	Manual control; electric actuator; pneumatic actuator

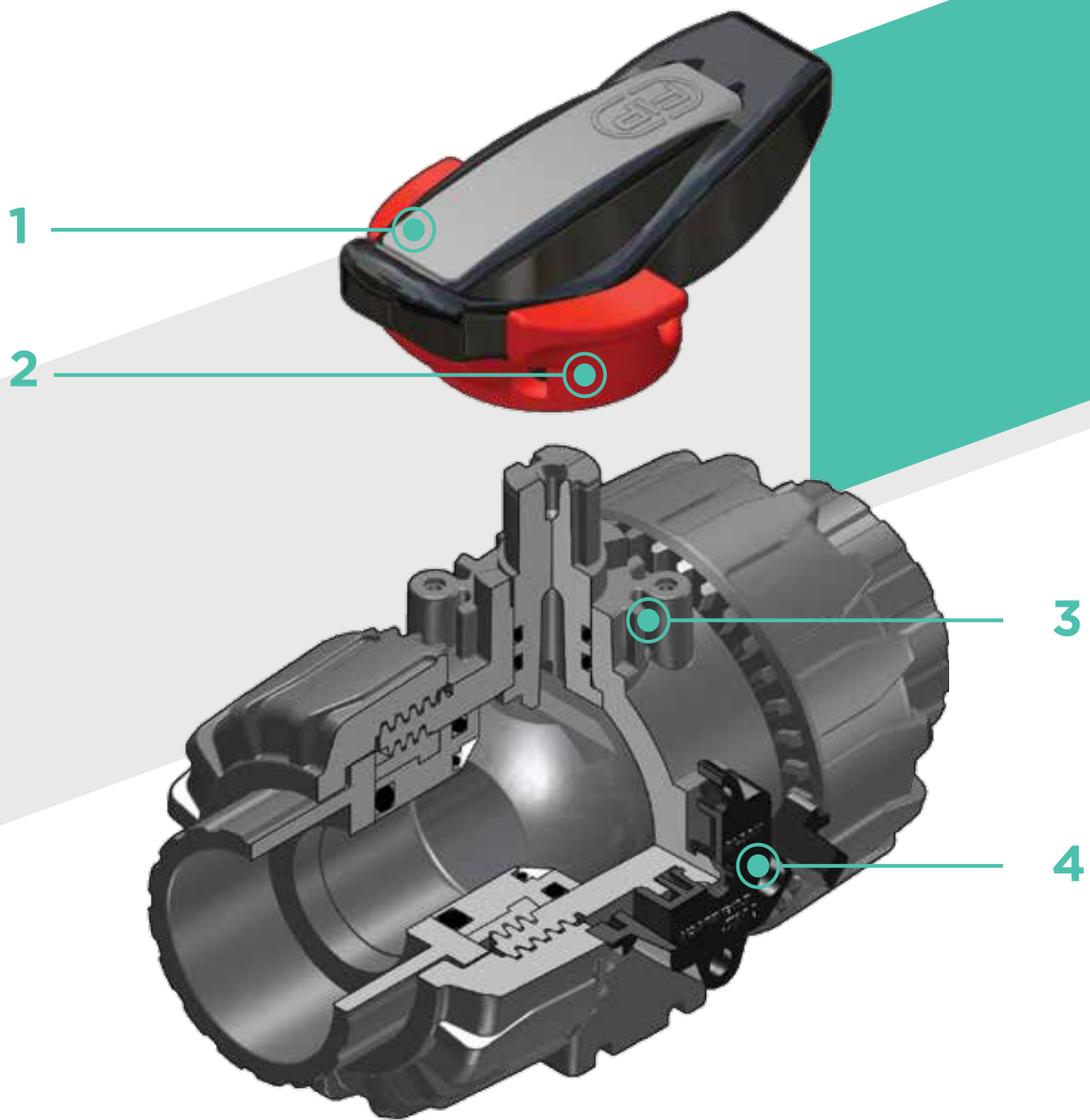

- 1 Ergonomic HIPVC handle equipped with **removable tool to adjust the ball seat carrier.**
- 2 **Handle lock 0°- 90° SHKD** (available as an accessory) ergonomically operable during service and padlockable

3 Robust **integrated bracket for valve anchoring**, for easy and quick automation even after valve installation on the system via the Power Quick module (optional)

4 **DUAL BLOCK®** patented lock system that ensures union nut tightening hold even in severe conditions such as vibrations or heat dilation

TECHNICAL DATA

PRESSURE VARIATION ACCORDING TO TEMPERATURE

For water and harmless fluids to which the material is classified as CHEMICALLY RESISTANT. In other cases, a reduction of the nominal PN pressure is required (25 years with safety factor).

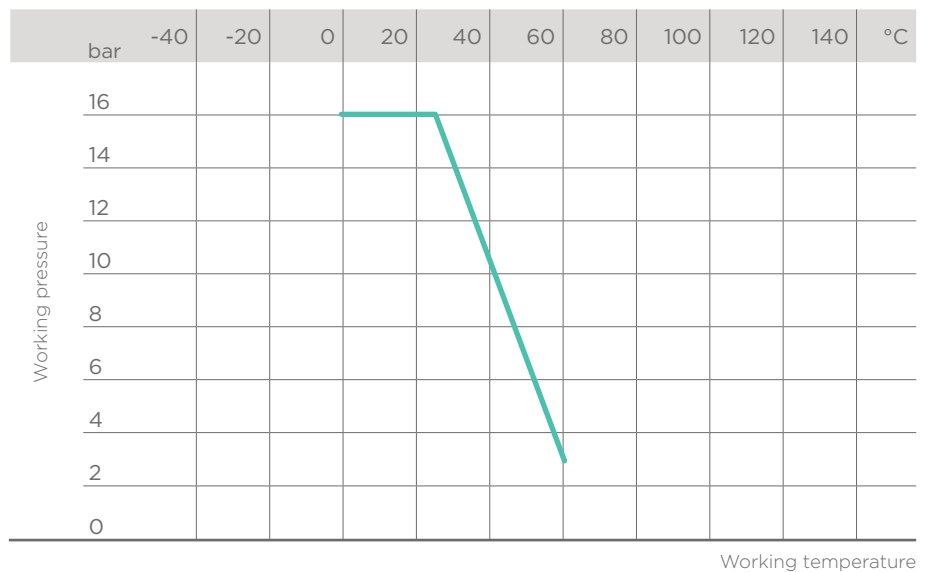

PRESSURE DROP GRAPH

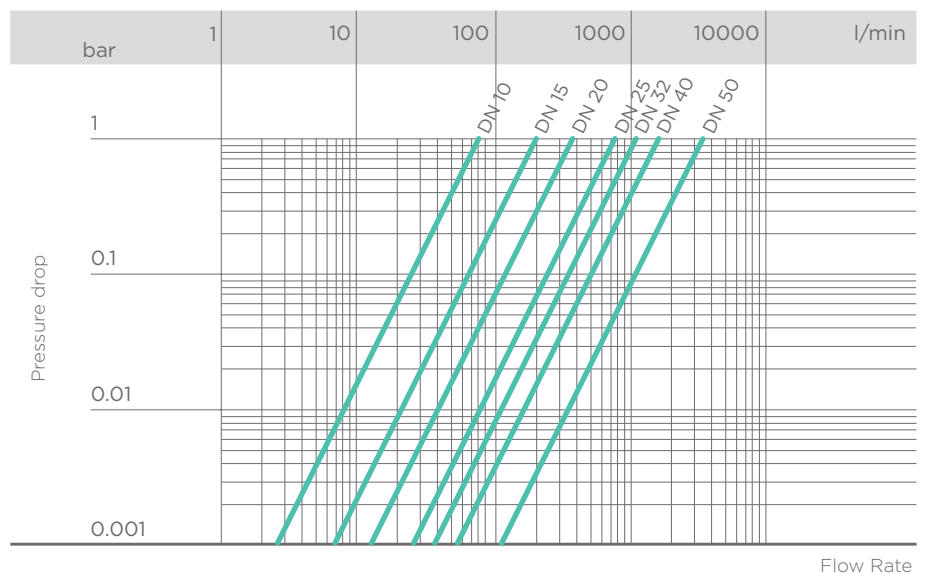

K_v100 FLOW COEFFICIENT

The K_v100 flow coefficient is the Q flow rate of litres per minute of water at a temperature of 20°C that will generate Δp= 1 bar pressure drop at a certain valve position.

The K_v100 values shown in the table are calculated with the valve completely open.

DN	10	15	20	25	32	40	50
K _v 100 l/min	80	200	385	770	1100	1750	3400

OPERATING TORQUE AT MAXIMUM WORKING PRESSURE

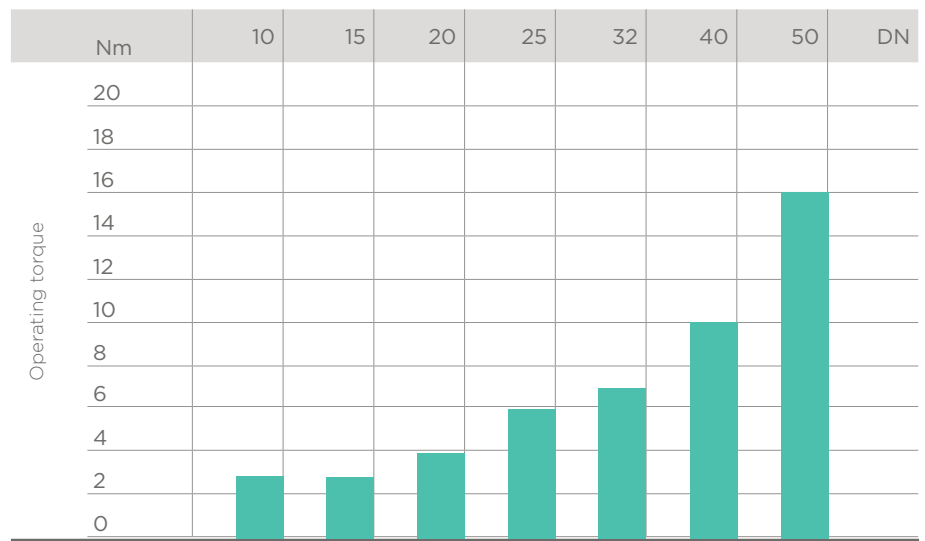

The information in this leaflet is provided in good faith. No liability will be accepted concerning technical data that is not directly covered by recognised international standards. FIP reserves the right to carry out any modification. Products must be installed and maintained by qualified personnel.

DIMENSIONS

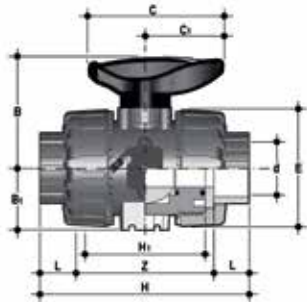

VKDIV

DUAL BLOCK® 2-way ball valve with female ends for solvent welding, metric series

d	DN	PN	B	B ₁	C	C ₁	E	H	H ₁	L	Z	g	EPDM Code	FPM Code
16	10	16	54	29	67	40	54	103	65	14	75	215	VKDIV016E	VKDIV016F
20	15	16	54	29	67	40	54	103	65	16	71	205	VKDIV020E	VKDIV020F
25	20	16	65	34.5	85	49	65	115	70	19	77	330	VKDIV025E	VKDIV025F
32	25	16	69.5	39	85	49	73	128	78	22	84	438	VKDIV032E	VKDIV032F
40	32	16	82.5	46	108	64	86	146	88	26	94	693	VKDIV040E	VKDIV040F
50	40	16	89	52	108	64	98	164	93	31	102	925	VKDIV050E	VKDIV050F
63	50	16	108	62	134	76	122	199	111	38	123	1577	VKDIV063E	VKDIV063F

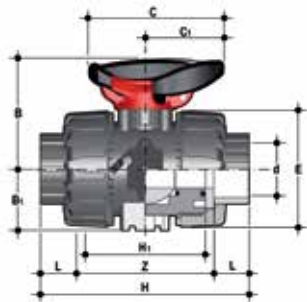

VKDIV/SHX

DUAL BLOCK® 2-way ball valve with handle lock and STAINLESS steel threaded inserts with female ends for solvent welding, metric series

d	DN	PN	B	B ₁	C	C ₁	E	H	H ₁	L	Z	g	EPDM Code	FPM Code
16	10	16	54	29	67	40	54	103	65	14	75	225	VKDIVSHX016E	VKDIVSHX016F
20	15	16	54	29	67	40	54	103	65	16	71	215	VKDIVSHX020E	VKDIVSHX020F
25	20	16	65	34.5	85	49	65	115	70	19	77	340	VKDIVSHX025E	VKDIVSHX025F
32	25	16	69.5	39	85	49	73	128	78	22	84	448	VKDIVSHX032E	VKDIVSHX032F
40	32	16	82.5	46	108	64	86	146	88	26	94	703	VKDIVSHX040E	VKDIVSHX040F
50	40	16	89	52	108	64	98	164	93	31	102	935	VKDIVSHX050E	VKDIVSHX050F
63	50	16	108	62	134	76	122	199	111	38	123	1587	VKDIVSHX063E	VKDIVSHX063F

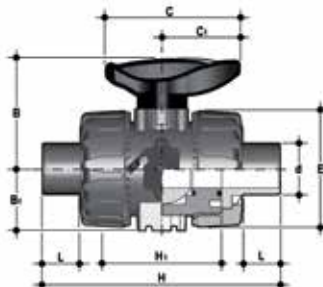

VKDDV

DUAL BLOCK® 2-way ball valve with male ends for solvent welding, metric series

d	DN	PN	B	B ₁	C	C ₁	E	H	H ₁	L	g	EPDM Code	FPM Code
16	10	16	54	29	67	40	54	149	65	14	215	VKDDV016E	VKDDV016F
20	15	16	54	29	67	40	54	124	65	16	220	VKDDV020E	VKDDV020F
25	20	16	65	34.5	85	49	65	144	70	19	340	VKDDV025E	VKDDV025F
32	25	16	69.5	39	85	49	73	154	78	22	443	VKDDV032E	VKDDV032F
40	32	16	82.5	46	108	64	86	174	88	26	693	VKDDV040E	VKDDV040F
50	40	16	89	52	108	64	98	194	93	31	945	VKDDV050E	VKDDV050F
63	50	16	108	62	134	76	122	224	111	38	1607	VKDDV063E	VKDDV063F

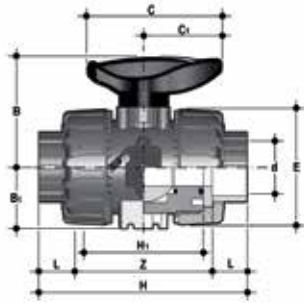

VKDLV

DUAL BLOCK® 2-way ball valve with female ends for solvent welding, BS series

d	DN	PN	B	B ₁	C	C ₁	E	H	H ₁	L	Z	g	EPDM Code	FPM Code
3/8"	10	16	54	29	67	40	54	103	65	14.5	74	210	VKDLV038E	VKDLV038F
1/2"	15	16	54	29	67	40	54	103	65	16.5	70	205	VKDLV012E	VKDLV012F
3/4"	20	16	65	34.5	85	49	65	115	70	19	77	335	VKDLV034E	VKDLV034F
1"	25	16	69.5	39	85	49	73	128	78	22.5	83	433	VKDLV100E	VKDLV100F
1" 1/4	32	16	82.5	46	108	64	86	146	88	26	94	703	VKDLV114E	VKDLV114F
1" 1/2	40	16	89	52	108	64	98	164	93	30	104	925	VKDLV112E	VKDLV112F
2"	50	16	108	62	134	76	122	199	111	36	127	1647	VKDLV200E	VKDLV200F

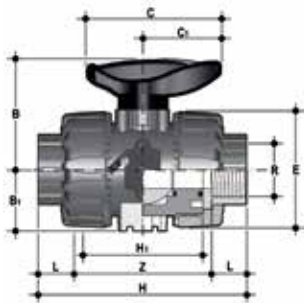

VKDFV

DUAL BLOCK® 2-way ball valve with BSP threaded female ends

R	DN	PN	B	B ₁	C	C ₁	E	H	H ₁	L	Z	g	EPDM Code	FPM Code
3/8"	10	16	54	29	67	40	54	103	65	12**	80	215	VKDFV038E	VKDFV038F
1/2"	15	16	54	29	67	40	54	110	65	15	80	210	VKDFV012E	VKDFV012F
3/4"	20	16	65	34.5	85	49	65	116	70	16	83	335	VKDFV034E	VKDFV034F
1"	25	16	69.5	39	85	49	73	134	78	19	96	448	VKDFV100E	VKDFV100F
1" 1/4	32	16	82.5	46	108	64	86	153	88	21	110	678	VKDFV114E	VKDFV114F
1" 1/2	40	16	89	52	108	64	98	156	93	21	113	955	VKDFV112E	VKDFV112F
2"	50	16	108	62	134	76	122	186	111	26	135	1667	VKDFV200E	VKDFV200F

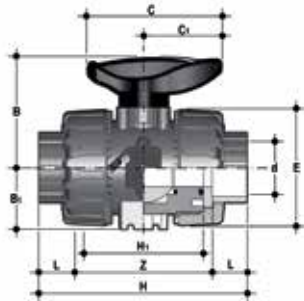

VKDAV

DUAL BLOCK® 2-way ball valve with female ends for solvent welding, ASTM series

d	DN	PN	B	B ₁	C	C ₁	E	H	H ₁	L	Z	g	EPDM Code	FPM Code
3/8"	10	16	54	29	67	40	54	117	65	19.5	78	230	VKDAV038E	VKDAV038F
1/2"	15	16	54	29	67	40	54	117	65	22.5	72	215	VKDAV012E	VKDAV012F
3/4"	20	16	65	34.5	85	49	65	129	70	25.5	78	345	VKDAV034E	VKDAV034F
1"	25	16	69.5	39	85	49	73	142	78	28.7	84.6	448	VKDAV100E	VKDAV100F
1" 1/4	32	16	82.5	46	108	64	86	162	88	32	98	718	VKDAV114E	VKDAV114F
1" 1/2	40	16	89	52	108	64	98	172	93	35	102	975	VKDAV112E	VKDAV112F
2"	50	16	108	62	134	76	122	199	111	38.2	122.6	1712	VKDAV200E	VKDAV200F

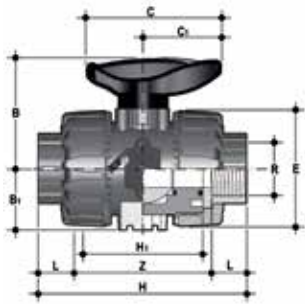

VKDNU

DUAL BLOCK® 2-way ball valve with female ends, NPT thread

R	DN	PN	B	B ₁	C	C ₁	E	H	H ₁	L	Z	g	EPDM Code	FPM Code
3/8"	10	16	54	29	67	40	54	103	65	13.7	75.6	215	VKDNU038E	VKDNU038F
1/2"	15	16	54	29	67	40	54	111	65	17.8	75.4	210	VKDNU012E	VKDNU012F
3/4"	20	16	65	34.5	85	49	65	117	70	18	81	335	VKDNU034E	VKDNU034F
1"	25	16	69.5	39	85	49	73	135	78	22.6	89.8	448	VKDNU100E	VKDNU100F
1" 1/4	32	16	82.5	46	108	64	86	153	88	25.1	102.8	678	VKDNU114E	VKDNU114F
1" 1/2	40	16	89	52	108	64	98	156	93	24.7	106.6	955	VKDNU112E	VKDNU112F
2"	50	16	108	62	134	76	122	186	111	29.6	126.8	1667	VKDNU200E	VKDNU200F

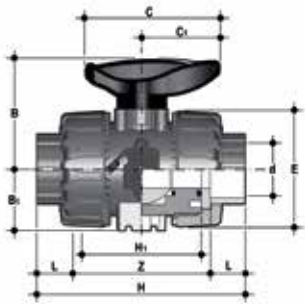

VKDJV

DUAL BLOCK® 2-way ball valve with female ends for solvent welding, JIS series

d	DN	PN	B	B ₁	C	C ₁	E	H	H ₁	L	Z	g	EPDM Code	FPM Code
1/2"	15	16	54	29	67	40	54	131	65	30	71	225	VKDJV012E	VKDJV012F
3/4"	20	16	65	34.5	85	49	65	147	70	35	77	335	VKDJV034E	VKDJV034F
1"	25	16	69.5	39	85	49	73	164	78	40	84	448	VKDJV100E	VKDJV100F
1" 1/4	32	16	82.5	46	108	64	86	182	88	44	94	728	VKDJV114E	VKDJV114F
1" 1/2	40	16	89	52	108	64	98	212	93	55	102	1015	VKDJV112E	VKDJV112F
2"	50	16	108	62	134	76	122	248	111	63	122	1727	VKDJV200E	VKDJV200F



VKDG

DUAL BLOCK® 2-way ball valve with female ends, JIS thread

R	DN	PN	B	B ₁	C	C ₁	E	H	H ₁	L	Z	g	EPDM Code	FPM Code
1/2"	15	16	54	29	67	40	54	103	65	16	71	210	VKDG012E	VKDG012F
3/4"	20	16	65	34.5	85	49	65	115	70	19	77	330	VKDG034E	VKDG034F
1"	25	16	69.5	39	85	49	73	128	78	22	84	438	VKDG100E	VKDG100F
1" 1/4	32	16	82.5	46	108	64	86	146	88	25	96	678	VKDG114E	VKDG114F
1" 1/2	40	16	89	52	108	64	98	164	93	26	112	975	VKDG112E	VKDG112F
2"	50	16	108	62	134	76	122	199	111	31	137	1627	VKDG200E	VKDG200F

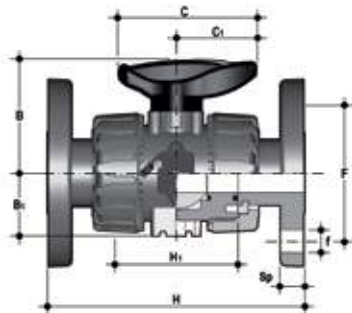

VKDOV

DUAL BLOCK® 2-way ball valve with EN/ISO/DIN PN 10/16 fixed flanges, Face to face according to EN 558-1

d	DN	PN	B	B ₁	C	C ₁	F	f	H	H ₁	Sp	U	g	EPDM Code	FPM Code
20	15	16	54	29	67	40	65	14	130	65	11	4	375	VKDOV020E	VKDOV020F
25	20	16	65	34.5	85	49	75	14	150	70	14	4	590	VKDOV025E	VKDOV025F
32	25	16	69.5	39	85	49	85	14	160	78	14	4	713	VKDOV032E	VKDOV032F
40	32	16	82.5	46	108	64	100	18	180	88	14	4	1108	VKDOV040E	VKDOV040F
50	40	16	89	52	108	64	110	18	200	93	16	4	1485	VKDOV050E	VKDOV050F
63	50	16	108	62	134	76	125	18	230	111	16	4	2347	VKDOV063E	VKDOV063F

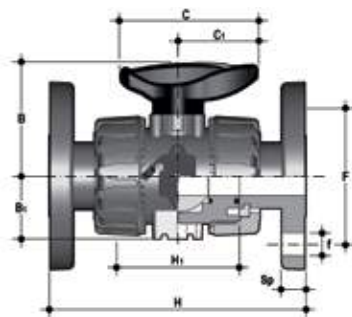

VKDOAV

DUAL BLOCK® 2-way ball valve with fixed flange, drilled ANSI B16.5 cl.150#FF

d	DN	PN	B	B ₁	C	C ₁	F	f	H	H ₁	Sp	U	g	EPDM Code	FPM Code
1/2"	15	16	54	29	67	40	60.3	15.9	143	65	11	4	460	VKDOAV012E	VKDOAV012F
3/4"	20	16	65	34.5	85	49	69.9	15.9	172	70	14	4	632	VKDOAV034E	VKDOAV034F
1"	25	16	69.5	39	85	49	79.4	15.9	187	78	14	4	853	VKDOAV100E	VKDOAV100F
1" 1/4	32	16	82.5	46	108	64	88.9	15.9	190	88	14	4	1313	VKDOAV114E	VKDOAV114F
1" 1/2	40	16	89	52	108	64	98.4	15.9	212	93	16	4	1669	VKDOAV112E	VKDOAV112F
2"	50	16	108	62	134	76	120.7	19.1	234	111	16	4	2577	VKDOAV200E	VKDOAV200F

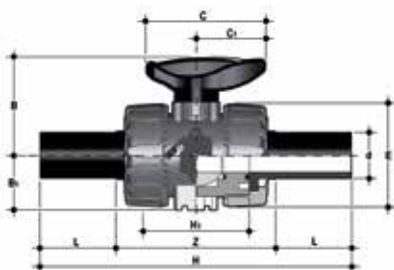

VKDBEV

DUAL BLOCK® 2-way ball valve with PE100 SDR 11 male end connectors for butt welding or electrofusion (CVDE)

d	DN	PN	B	B ₁	C	C ₁	E	H	H ₁	L	Z	g	EPDM Code	FPM Code
20	15	16	54	29	67	40	54	175	65	41	94	220	VKDBEV020E	VKDBEV020F
25	20	16	65	34.5	85	49	65	210	70	52	106	340	VKDBEV025E	VKDBEV025F
32	25	16	69.5	39	85	49	73	226	78	55	117	443	VKDBEV032E	VKDBEV032F
40	32	16	82.5	46	108	64	86	243	88	56	131	693	VKDBEV040E	VKDBEV040F
50	40	16	89	52	108	64	98	261	93	58	145	945	VKDBEV050E	VKDBEV050F
63	50	16	108	62	134	76	122	293	111	66	161	1607	VKDBEV063E	VKDBEV063F

ACCESSORIES

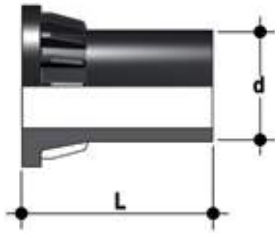

CVDE

Long spigot PE100 end connectors for joints with electrofusion fittings or for butt welding

d	DN	PN	L	SDR	Code
20	15	16	55	11	CVDE11020
25	20	16	70	11	CVDE11025
32	25	16	74	11	CVDE11032
40	32	16	78	11	CVDE11040
52	40	16	84	11	CVDE11050
63	50	16	91	11	CVDE11063



SHKD

Handle block kit 0° - 90° lockable

d	DN	Code
16 - 20	10 - 15	SHKD020
25 - 32	20 - 25	SHKD032
40 - 50	32 - 40	SHKD050
63	50	SHKD063

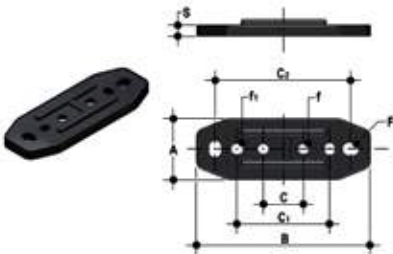

PMKD

Mounting plate

d	DN	A	B	C	C ₁	C ₂	F	f	f ₁	S	Code
16	10	30	86	20	46	67.5	6.5	5.3	5.5	5	PMKD1
20	15	30	86	20	46	67.5	6.5	5.3	5.5	5	PMKD1
25	20	30	86	20	46	67.5	6.5	5.3	5.5	5	PMKD1
32	25	30	86	20	46	67.5	6.5	5.3	5.5	5	PMKD1
40	32	40	122	30	72	102	6.5	6.3	6.5	6	PMKD2
50	40	40	122	30	72	102	6.5	6.3	6.5	6	PMKD2
63	50	40	122	30	72	102	6.5	6.3	6.5	6	PMKD2

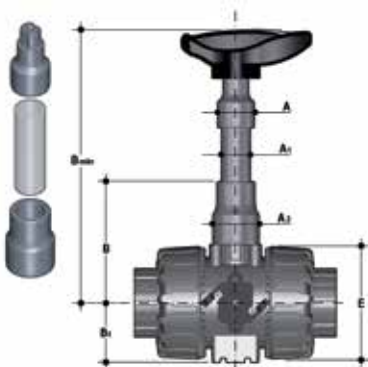

PSKD

Stem extension

d	DN	A	A ₁	A ₂	E	B	B ₁	B min	Code
16	10	32	25	32	54	70	29	139.5	PSKD020
20	15	32	25	32	54	70	29	139.5	PSKD020
25	20	32	25	40	65	89	34.5	164.5	PSKD025
32	25	32	25	40	73	93.5	39	169	PSKD032
40	32	40	32	50	86	110	46	200	PSKD040
50	40	40	32	50	98	116	52	206	PSKD050
63	50	40	32	59	122	122	62	225	PSKD063



EASYTORQUE KIT

Kit for ball seat carrier tightening adjustment for DUAL BLOCK® DN 10÷50 series valves

d	DN	Tightening torque recommended*	Code
3/8"-1/2"	10-15	3 N m - 2,21 Lbf ft	KETO1
3/4"	20	4 N m - 2,95 Lbf ft	KETO1
1"	25	5 N m - 3,69 Lbf ft	KETO1
1" 1/4	32	5 N m - 3,69 Lbf ft	KETO1
1" 1/2	40	7 N m - 5,16 Lbf ft	KETO1
2"	50	9 N m - 6,64 Lbf ft	KETO1

*calculated in ideal installation conditions



POWER QUICK CP

The valve can be equipped with pneumatic actuators, using the PP-GR module reproducing the drilling pattern foreseen by ISO 5211

d	DN	B ₂	Q	T	p x j	P x J	Code
16	10	58	11	12	F03 x 5,5	F04 x 5,5	PQCP020
20	15	58	11	12	F03 x 5,5	F04 x 5,5	PQCP020
25	20	69	11	12	*F03 x 5,5	F05 x 6,5	PQCP025
32	25	74	11	12	*F03 x 5,5	F05 x 6,5	PQCP032
40	32	91	14	16	F05 x 6,5	F07 x 8,5	PQCP040
50	40	97	14	16	F05 x 6,5	F07 x 8,5	PQCP050
63	50	114	14	16	F05 x 6,5	F07 x 8,5	PQCP063

*F04 x 5.5 on request



POWER QUICK CE

The valve can be equipped with electric actuators, using the PP-GR module reproducing the drilling pattern foreseen by ISO 5211

d	DN	B ₂	Q	T	p x j	P x J	Code
16	10	58	14	16	F03 x 5,5	F04 x 5,5	PQCE020
20	15	58	14	16	F03 x 5,5	F04 x 5,5	PQCE020
25	20	69	14	16	*F03 x 5,5	F05 x 6,5	PQCE025
32	25	74	14	16	*F03 x 5,5	F05 x 6,5	PQCE032
40	32	91	14	16	F05 x 6,5	F07 x 8,5	PQCE040
50	40	97	14	16	F05 x 6,5	F07 x 8,5	PQCE050
63	50	114	14	16	F05 x 6,5	F07 x 8,5	PQCE063

*F04 x 5.5 on request

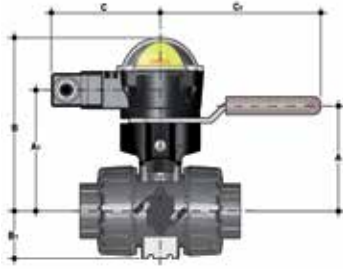

MSKD

MSKD is a limit switch box with electromechanical or inductive micro switches to remotely signal the valve position. Manual valve installation is possible using the Power Quick actuation module.

The box can be assembled on the VKD valve even if already installed on the system.

d	DN	A	A ₁	B	B ₁	C	C ₁	Code electromechanical	Code inductive	Code. Namur
16	10	58	85	132.5	29	88.5	134	MSKD1M	MSKD1I	MSKD1N
20	15	58	85	132.5	29	88.5	134	MSKD1M	MSKD1I	MSKD1N
25	20	70.5	96	143.5	34.5	88.5	134	MSKD1M	MSKD1I	MSKD1N
32	25	74	101	148.5	39	88.5	134	MSKD1M	MSKD1I	MSKD1N
40	32	116	118	165.5	46	88.5	167	MSKD2M	MSKD2I	MSKD2N
50	40	122	124	171.5	52	88.5	167	MSKD2M	MSKD2I	MSKD2N
63	50	139	141	188.5	62	88.5	167	MSKD2M	MSKD2I	MSKD2N

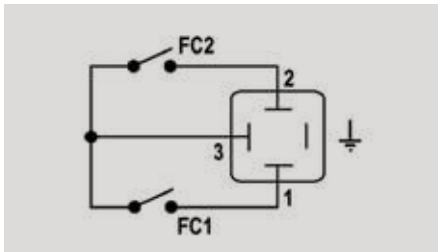

Electromechanical

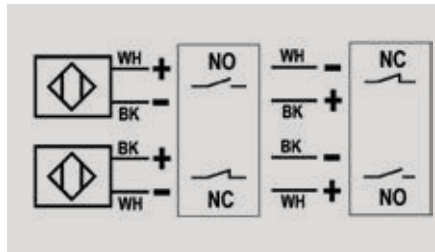

Inductive

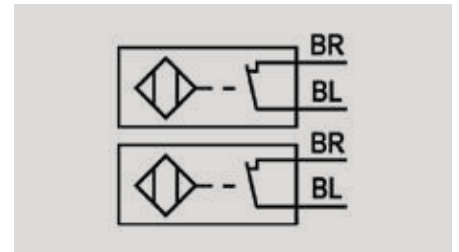

Namur

WH = white; BK = black; BL = blue; BR = brown

Switch type	Flow rate	Lifetime [drives]	Operating voltage	Nominal voltage	Working pressure	Voltage drop	No-load supply current	Protection rate
Electromechanical	250 V - 5 A	3×10^7	-	-	-	-	-	IP65
Inductive	-	-	$5 \div 36$ V	-	$4 \div 200$ mA	$< 4,6$ V	$< 0,8$ mA	IP65
Namur*	-	-	$7,5 \div 30$ V DC**	8,2 V DC	< 30 mA**	-	-	IP65

* To be used with an amplifier

** Outside areas with explosion risks

FASTENING AND SUPPORTING



All valves, whether manual or actuated, must be adequately supported in many applications.

The VKD valve series is therefore provided with an integrated bracket that permits direct anchoring of the valve body without the need of other components.

For wall installation, dedicated PMKD mounting plates which are available as accessories can be used. These plates should be fastened to the valve before wall installation.

PMKD plates also allow VKD valve alignment with FIP ZIKM pipe clips as well as allowing different sizes of valves to be aligned.

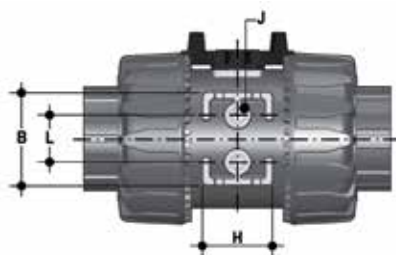

d	DN	B	H	L	J*
16	10	31.5	27	20	M4 x 6
20	15	31.5	27	20	M4 x 6
25	20	40	30	20	M4 x 6
32	25	40	30	20	M4 x 6
40	32	50	35	20	M6 x 10
50	40	50	35	20	M6 x 10
63	50	60	40	20	M6 x 10

* With threaded inserts

COMPONENTS

EXPLODED VIEW

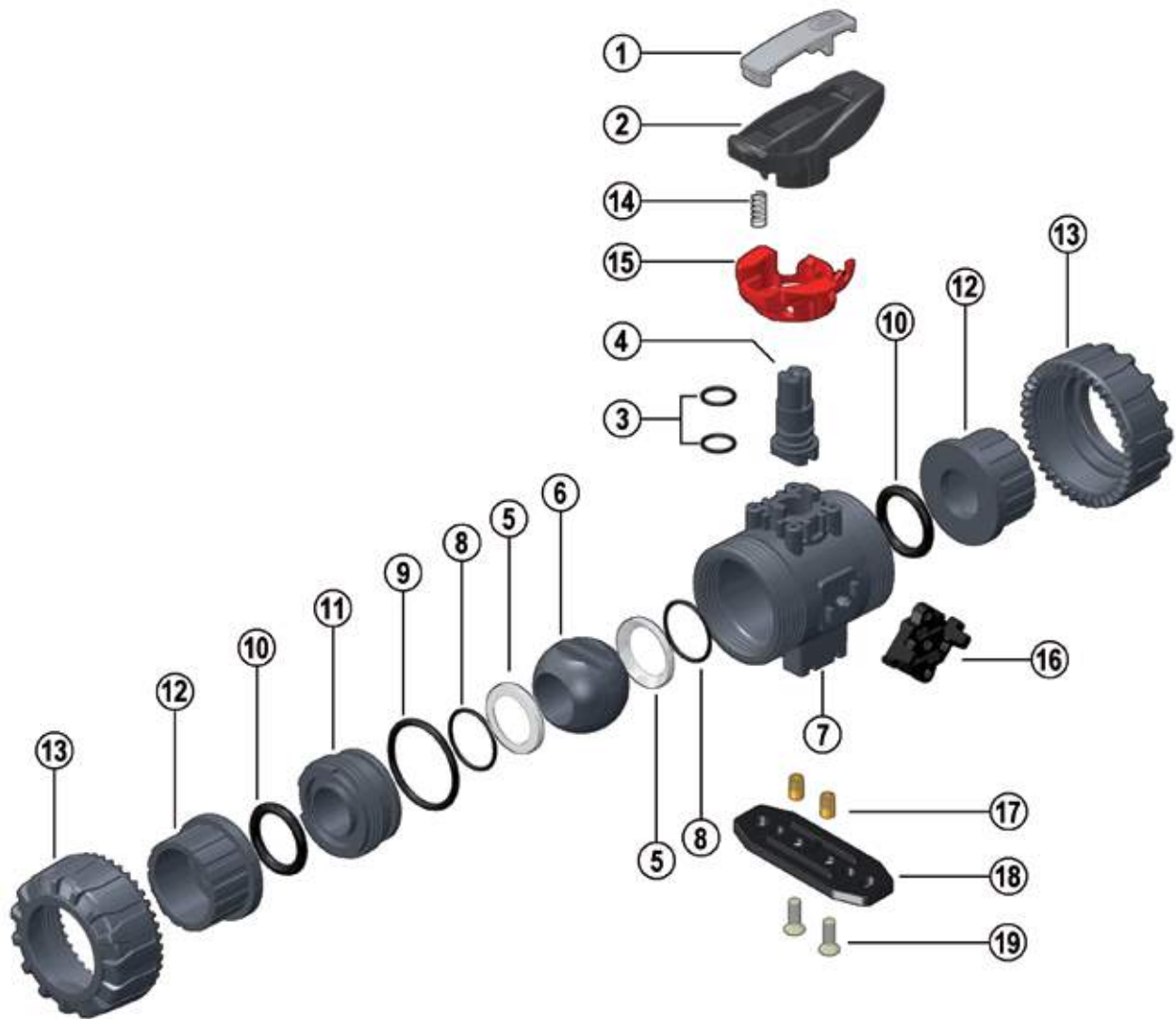

1 · Handle insert (PVC-U - 1)

2 · Handle (HIPVC - 1)

3 · Stem O-rings
(EPDM-FPM - 2)*

4 · Stem (PVC-U - 1)

5 · Ball seat
(PTFE - 2)*

6 · Ball (PVC-U - 1)

7 · Body (PVC-U - 1)

8 · Ball seat O-Rings
(EPDM-FPM - 2)*

9 · Radial seal O-Ring
(EPDM-FPM - 1)

10 · Socket seal O-Ring
(EPDM-FPM - 2)

11 · Ball seat carrier
(PVC-U - 1)

12 · End connector (PVC-U - 2)

13 · Union nut (PVC-U - 2)

14 · Spring (STAINLESS steel - 1)**

15 · Handle safety
block (PP-GR - 1)**

16 · DUAL BLOCK® (POM - 1)

17 · Threaded inserts
(STAINLESS steel or Brass - 2)**

18 · Distance plate (PP-GR - 1)**

19 · Screw (STAINLESS steel - 2)**

* Spare parts

** Accessories

The component material and quantity supplied are indicated in the parentheses.

DISMOUNTING

- 1) Isolate the valve from the line (release the pressure and empty the pipeline).
- 2) Unlock the union nuts by pressing the lever on the DUAL BLOCK® (16) along the axis and separate it from the union nut (fig. 1-2). It is also possible to completely remove the block device from the body of the valve.
- 3) Fully unscrew the union nuts (13) and extract the body sideways.
- 4) Before dismounting, hold the valve in a vertical position and open it 45° to drain any liquid that might remain.
- 5) After closing the valve, remove the special insert (1) from the handle (2) and push the two projecting ends into the corresponding recesses on the ball seat carrier (11). Rotate the stop ring anti-clockwise to extract it (fig. 3-4).
- 6) Pull the handle (2) upwards to remove it from the valve stem (4).
- 7) Press on the ball from the side opposite the "REGULAR - ADJUST" label, being sure not to scratch it, until the ball seat carrier exits (11), then extract the ball (6).
- 8) Press the stem (4) inwards until it exits the body.
- 9) Remove the O-Ring (3, 8, 9, 10) and PTFE ball seats (5) extracting them from their grooves, as illustrated in the exploded view.

ASSEMBLY

- 1) All the O-rings (3, 8, 9, 10) must be inserted in their grooves as shown in the exploded view.
- 2) Insert the stem (4) from inside the valve body (7).
- 3) Place the PTFE ball seats (5) in the housings in the body (7) and in the ball seat ball seat carrier (11).
- 4) Insert the ball (6) rotating it to the closed position.
- 5) Screw the carrier (11) into the body and tighten up in the clockwise direction using the handle (2) to limit stop.
- 6) Insert the valve between the end connectors (12) and tighten the union nuts (13) making sure that the socket seal O-rings (10) do not exit their seats.
- 7) The handle (2) should be placed on the valve stem (4).



Note: during assembly operations, it is advisable to lubricate the rubber seals. Mineral oils are not recommended for this task as they react aggressively with EPDM rubber.

Fig. 1



Fig. 2



Fig. 3



Fig. 4



INSTALLATION

Before proceeding with installation, please follow these instructions carefully:

- 1) Check that the pipes to be connected to the valve are aligned in order to avoid mechanical stress on the threaded joints.
- 2) Check that the DUAL BLOCK® union nut locking device (16) is fitted to the valve body.
- 3) To release the union nuts, axially press the release lever to separate the lock and then unscrew it in the counter-clockwise direction.
- 4) Unscrew the union nuts (13) and insert them on the pipe segments.
- 5) Solvent weld or screw the end connectors (12) onto the pipe ends.
- 6) Position the valve body between the end connectors and fully tighten the union nuts (13) manually by rotating clockwise without using wrenches or other tools that could damage the union nut surface.
- 7) Lock the union nuts by returning the DUAL BLOCK® to its housing, pressing on it until the hinges lock on the union nuts.

8) If necessary, support the pipework with FIP pipe clips or by means of the carrier built into the valve itself (see paragraph "fastening and carriers").

The VKD valve can be equipped with a handle lock to prevent ball rotation (supplied separately).

When the handle safety block (14, 15) is installed, lift the lever (15) and rotate the handle (fig. 6-7).

A lock can also be installed on the handle to protect the system against tampering (fig. 8).

Seal can be adjusted using the extractable insert on the handle (fig. 3-4).

The seals can be adjusted later with the valve installed on the pipe by simply tightening the union nuts. This "micro adjustment", only possible with FIP valves thanks to the patented "Seat stop system", allows the seal to be recovered where PTFE ball seats are worn due to a high number of operations.

The Easytorque kit can also be used for micro adjustments (fig. 5).

WARNINGS

- If volatile liquid such as Hydrogen Peroxide (H₂O₂) or Sodium Hypochlorite (NaClO) are used, for safety reasons we recommend you contact the service centre. These liquids, upon vaporising, could create hazardous over pressures in the area between the body and ball.
- Always avoid sudden closing operations and protect the valve from accidental operations.

Fig. 5



Fig. 6



Fig. 7



Fig. 8





Aliaxis
UTILITIES & INDUSTRY

FIP - Formatura Iniezione Polimeri

Loc. Pian di Parata, 16015 Casella Genova Italy

Tel. +39 010 96211

Fax +39 010 9621.209

info.fip@aliaxis.com

www.fipnet.com



Code LEVAMAV



VKD DN 65÷100
PVC-U

DUAL BLOCK® 2-way ball valve

VKD DN 65÷100

FIP has developed a VKD DUAL BLOCK® ball valve to introduce a high reference standard in thermosplastic valve design. VKD is a True Union ball valve that meets the most stringent needs required by industrial applications. This valve is also equipped with a customisable Labelling System.



DUAL BLOCK® 2-WAY BALL VALVE

- Connection system for solvent weld, threaded and flanged joints
- Patented **SEAT STOP®** ball carrier system that lets you micro-adjust seals and minimise axial force effects
- Easy radial dismounting allowing quick replacement of O-rings and ball seats without any need for tools
- **PN16 True Union valve body** made for rigid PVC-U injection moulding equipped with built-in bores for actuation. ISO 9393 compliant test requisites
- Option of dismounting downstream pipes with the valve in the closed position
- **Full bore ball** with high surface finish
- **Integrated bracket** for valve anchoring
- Possibility of installing a manual reducer or pneumatic and/or electric actuators by applying an ISO standard bore PP-GR flange
- **STAINLESS steel co-moulded stem**, with square section as per ISO 5211

Technical specifications	
Construction	2-way True Union ball valve with locked carrier and union nuts.
Size range	DN 65 ÷ 100
Nominal pressure	PN 16 with water at 20° C
Temperature range	0 °C ÷ 60 °C
Coupling standards	<p>Solvent welding: EN ISO 1452, EN ISO 15493, BS 4346-1, DIN 8063, NF T54-028, ASTM D 2467, JIS K 6743. Pipe coupling as per EN ISO 1452, EN ISO 15493, DIN 8062, NF T54-016, ASTM D 1785, JIS K 6741.</p> <p>Thread: ISO 228-1, DIN2999, ASTM D 2467, JIS B 0203.</p> <p>Flanging system: ISO 7005-1, EN ISO 1452, EN ISO 15493, EN 588-1, DIN 2501, ANSI B.16.5 cl.150, JIS B 2220.</p>
Reference standards	<p>Construction criteria: EN ISO 16135, EN ISO 1452, EN ISO 15493</p> <p>Test methods and requirements: ISO 9393</p> <p>Installation criteria: DVS 2204, DVS 2221, UNI 11242</p> <p>Actuator couplings: ISO 5211</p>
Valve material	PVC-U
Seal material	EPDM, FPM; PTFE (ball seats)
Control options	Manual control; electric actuator; pneumatic actuator

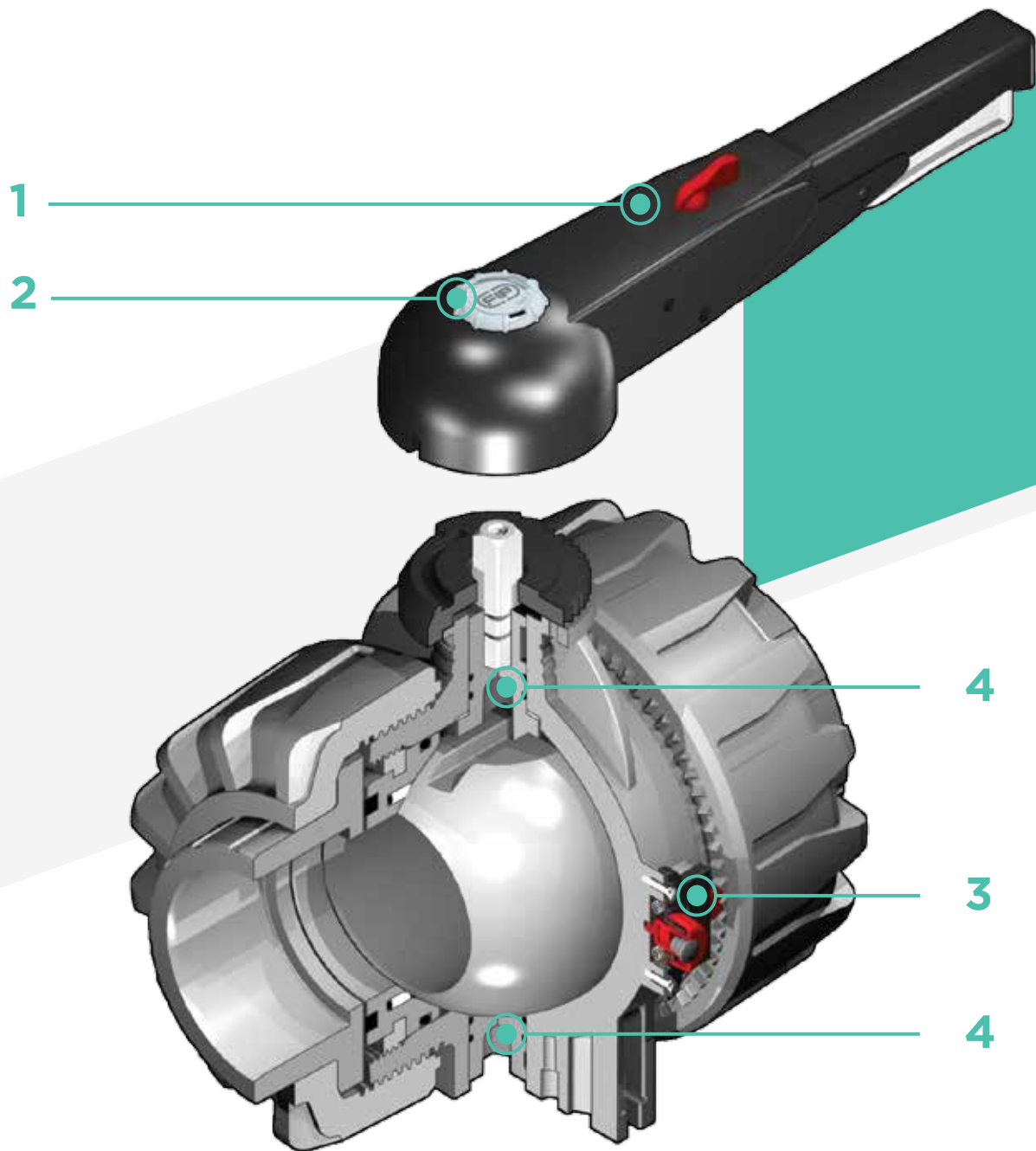

1 HIPVC ergonomic multifunctional handle for quick operation, **lock and graduated adjustment in 10 positions.** Possibility of inhibiting rotation with a lock

2 Customisable Labelling System: LCE module made of a transparent protection plug and **customisable tag holder** using the LSE set (available as accessory). The customisation lets you identify the valve on the system according to specific needs

3 **DUAL BLOCK®** patented lock system that ensures union nut tightening hold even in severe conditions such as vibrations or heat dilation

4 **Double stem** with double O-Rings for ball centring and operating torque reduction

TECHNICAL DATA

PRESSURE VARIATION ACCORDING TO TEMPERATURE

For water and harmless fluids to which the material is classified as CHEMICALLY RESISTANT. In other cases, a reduction of the nominal PN pressure is required (25 years with safety factor).

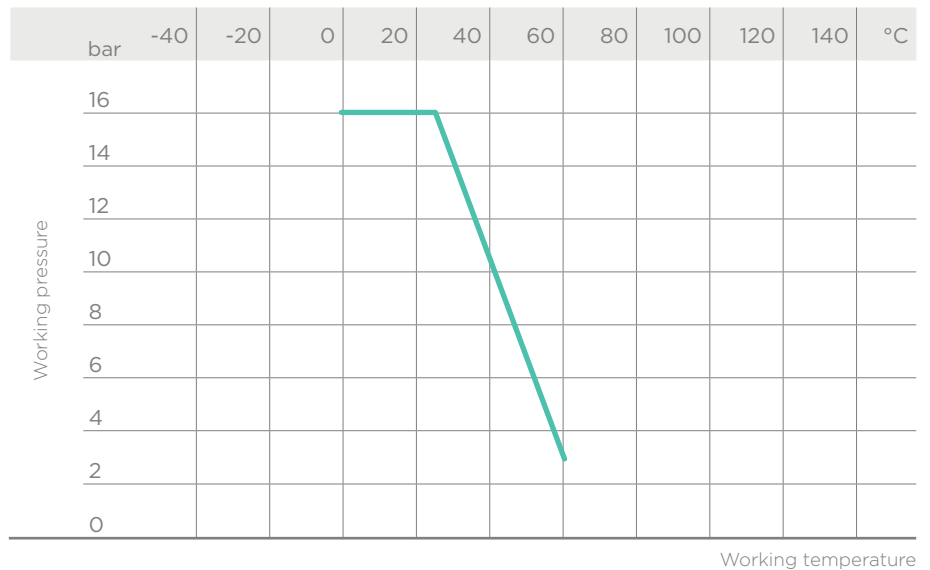

PRESSURE DROP GRAPH

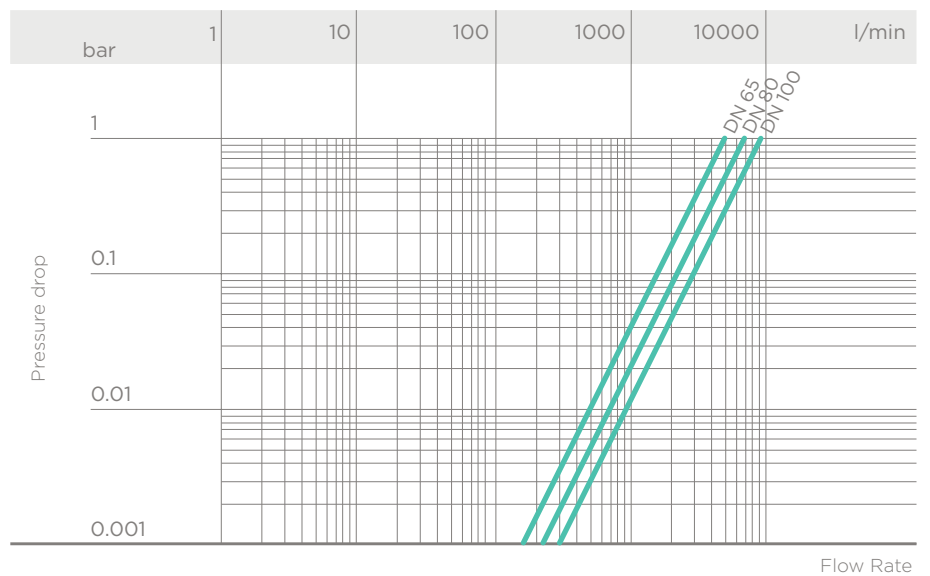

K_v100 FLOW COEFFICIENT

The K_v100 flow coefficient is the Q flow rate of litres per minute of water at a temperature of 20°C that will generate $\Delta p = 1$ bar pressure drop at a certain valve position.

The K_v100 values shown in the table are calculated with the valve completely open.

DN	65	80	100
K _v 100 l/min	5250	7100	9500

OPERATING TORQUE AT MAXIMUM WORKING PRESSURE

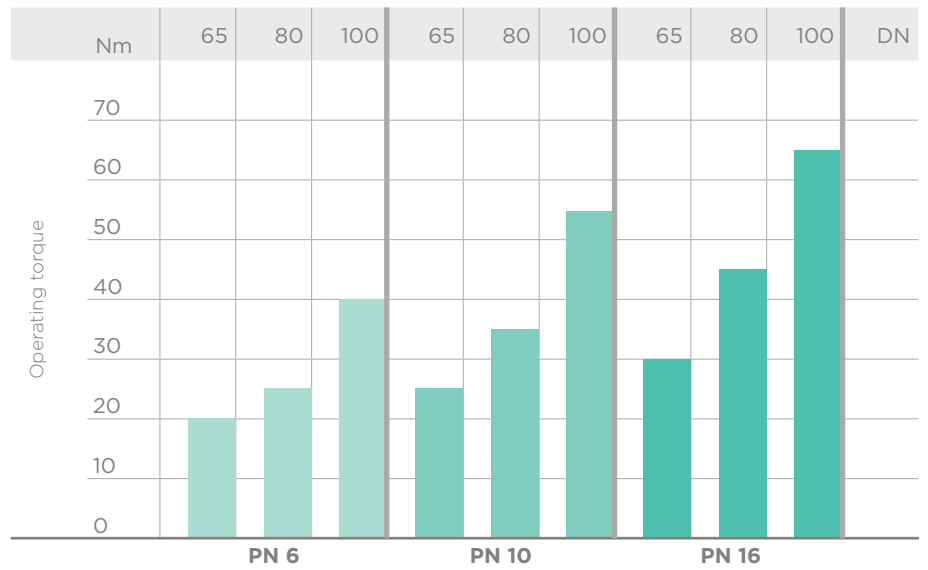

The information in this leaflet is provided in good faith. No liability will be accepted concerning technical data that is not directly covered by recognised international standards. FIP reserves the right to carry out any modification. Products must be installed and maintained by qualified personnel.

DIMENSIONS

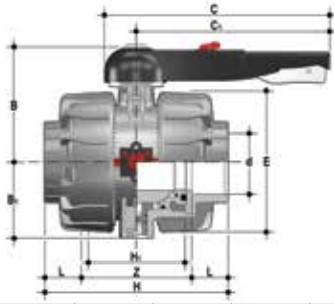

VKDIV

DUAL BLOCK® 2-way ball valve with female ends, metric series

d	DN	PN	B	B ₁	C	C ₁	E	H	H ₁	L	Z	g	EPDM Code	FPM Code
75	65	16	164	87	225	175	164	235	133	44	147	4380	VKDIV075E	VKDIV075F
90	80	16	177	105	327	272	203	270	149	51	168	7200	VKDIV090E	VKDIV090F
110	100	16	195	129	385	330	238	308	167	61	186	11141	VKDIV110E	VKDIV110F

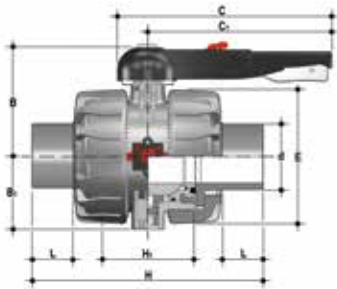

VKDDV

DUAL BLOCK® 2-way ball valve with male ends for solvent welding, metric series

d	DN	PN	B	B ₁	C	C ₁	E	H	H ₁	L	g	EPDM Code	FPM Code
75	65	16	164	87	225	175	164	284	133	44	4420	VKDDV075E	VKDDV075F
90	80	16	177	105	327	272	203	300	149	51	6930	VKDDV090E	VKDDV090F
110	100	16	195	129	385	330	238	340	167	61	10950	VKDDV110E	VKDDV110F

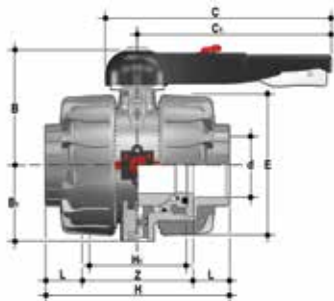

VKDLV

DUAL BLOCK® 2-way ball valve with female ends for solvent welding, BS series

d	DN	PN	B	B ₁	C	C ₁	E	H	H ₁	L	Z	g	EPDM Code	FPM Code
2" 1/2	65	16	164	87	225	175	164	235	133	44	147	4380	VKDLV212E	VKDLV212F
3"	80	16	177	105	327	272	203	270	149	51	168	7250	VKDLV300E	VKDLV300F
4"	100	16	195	129	385	330	238	308	167	63	182	10995	VKDLV400E	VKDLV400F

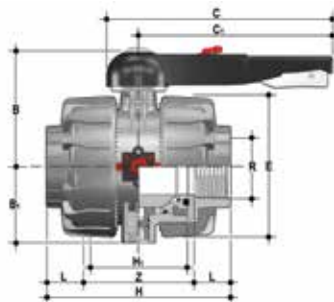

VKDFV

DUAL BLOCK® 2-way ball valve with BSP threaded female ends

R	DN	PN	B	B ₁	C	C ₁	E	H	H ₁	L	Z	g	EPDM Code	FPM Code
2" 1/2	65	16	164	87	225	175	164	235	133	30	175	4395	VKDFV212E	VKDFV212F
3"	80	16	177	105	327	272	203	270	149	34	203	7260	VKDFV300E	VKDFV300F
4"	100	16	195	129	385	330	238	308	167	40	229	11100	VKDFV400E	VKDFV400F

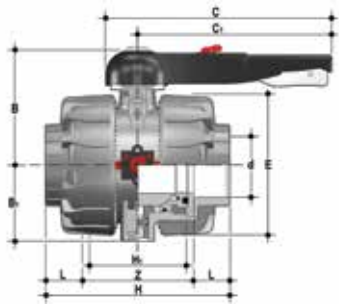

VKDAV

DUAL BLOCK® 2-way ball valve with female ends for solvent welding, ASTM series

d	DN	PN	B	B ₁	C	C ₁	E	H	H ₁	L	Z	g	EPDM Code	FPM Code
2" 1/2	65	16	164	87	225	175	164	235	133	44,5	146	4390	VKDAV212E	VKDAV212F
3"	80	16	177	105	327	272	203	270	149	48	174	7210	VKDAV300E	VKDAV300F
4"	100	16	195	129	385	330	238	308	167	57,5	193	11065	VKDAV400E	VKDAV400F

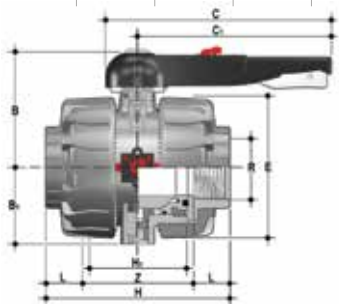

VKDNV

DUAL BLOCK® 2-way ball valve with female ends, NPT thread

R	DN	PN	B	B ₁	C	C ₁	E	H	H ₁	L	Z	g	EPDM Code	FPM Code
2" 1/2	65	16	164	87	225	175	164	235	133	33,2	168,6	4395	VKDNV212E	VKDNV212F
3"	80	16	177	105	327	272	203	270	149	35,5	199	7260	VKDNV300E	VKDNV300F
4"	100	16	195	129	385	330	238	308	167	37,6	232,8	11100	VKDNV400E	VKDNV400F

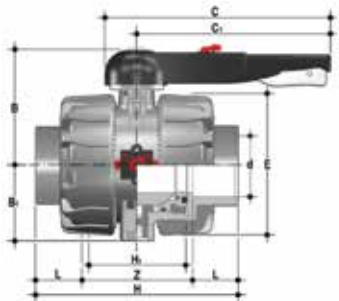

VKDJV

DUAL BLOCK® 2-way ball valve with female ends for solvent welding, JIS series

d	DN	PN	B	B ₁	C	C ₁	E	H	H ₁	L	Z	g	EPDM Code	FPM Code
2" 1/2	65	16	164	87	225	175	164	267	133	61	145	4435	VKDJV212E	VKDJV212F
3"	80	16	177	105	327	272	203	294	149	64,5	165	7250	VKDJV300E	VKDJV300F
4"	100	16	195	129	385	330	238	370	167	84	202	11580	VKDJV400E	VKDJV400F

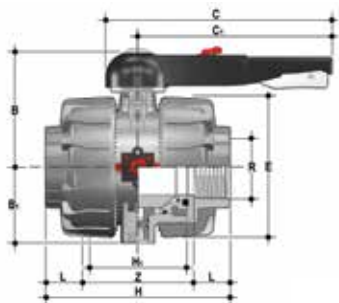

VKDGV

DUAL BLOCK® 2-way ball valve with female ends, JIS thread

R	DN	PN	B	B ₁	C	C ₁	E	H	H ₁	L	Z	g	EPDM Code	FPM Code
2" 1/2	65	16	164	87	225	175	164	235	133	35	165	4400	VKDGV212E	VKDGV212F
3"	80	16	177	105	327	272	203	270	149	40	190	7270	VKDGV300E	VKDGV300F
4"	100	16	195	129	385	330	238	308	167	45	218	11115	VKDGV400E	VKDGV400F

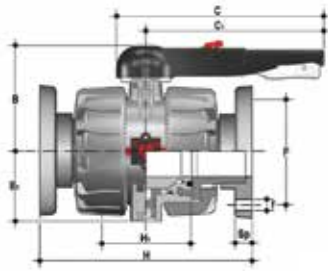

VKDOV

DUAL BLOCK® 2-way ball valve with fixed flanges, drilled PN10/16. Face to face according to EN 558-1

d	DN	PN	B	B ₁	C	C ₁	F	f	H	H ₁	Sp	U	g	EPDM Code	FPM Code
75	65	16	164	87	225	175	145	17	290	133	21	4	6610	VKDOV075E	VKDOV075F
90	80	16	177	105	327	272	160	17	310	149	21.5	8	9330	VKDOV090E	VKDOV090F
110	100	16	195	129	385	330	180	17	350	167	21.5	8	13815	VKDOV110E	VKDOV110F

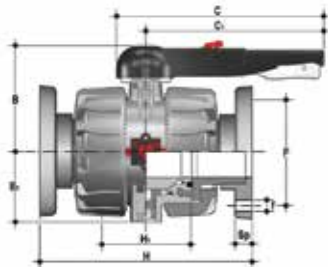

VKDOAV

DUAL BLOCK® 2-way ball valve with fixed flanges, drilled ANSI B.16.5 cl.150 #FF. Face to face according to EN 558-1

d	DN	PN	B	B ₁	C	C ₁	F	f	H	H ₁	Sp	U	g	EPDM Code	FPM Code
2" 1/2	65	16	164	87	225	175	139.7	18	290	133	21	4	6610	VKDOAV075E	VKDOAV075F
3"	80	16	177	105	327	272	152.4	18	310	149	21.5	8	9330	VKDOAV090E	VKDOAV090F
4"	100	16	195	129	385	330	190.5	18	350	167	21.5	8	13815	VKDOAV110E	VKDOAV110F

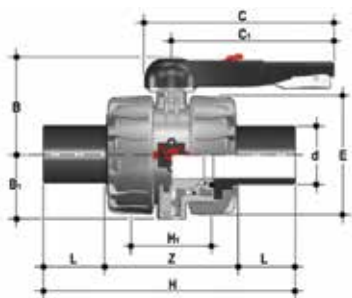

VKDBEV

DUAL BLOCK® 2-way valve with PE100 SDR 11 male end connectors for butt welding or electrofusion (CVDE)

d	DN	PN	B	B ₁	C	C ₁	E	H	H ₁	L	Z	g	EPDM Code	FPM Code
75	65	16	164	87	225	175	162	356	133	71	214	4400	VKDOV075E	VKDOV075F
90	80	16	177	105	327	272	202	390	149	88	214	7100	VKDOV090E	VKDOV090F
110	100	16	195	129	385	330	236	431	167	92	247	10800	VKDOV110E	VKDOV110F

ACCESSORIES

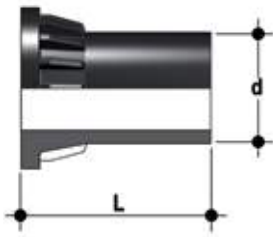

CVDE

Long spigot PE100 end connectors for joints with electrofusion fittings or for butt welding

d	DN	PN	L	SDR	Code
75	65	16	111	11	CVDE11075
90	80	16	118	11	CVDE11090
110	100	16	132	11	CVDE11110



LSE

Customisation and label printing set for Easyfit handle made up of pre-cut adhesive sheets and software for guided label creation.

d	DN	Code
75	65	LSE040
90	80	LSE040
110	100	LSE040

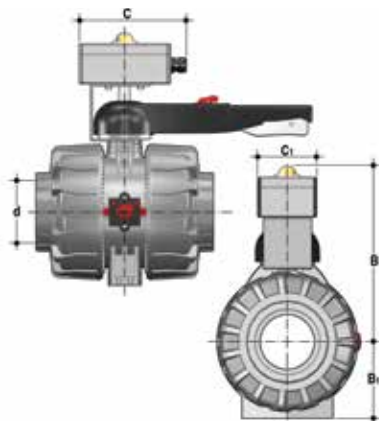

VKD-MS

The MS kit lets you install a limit switch valve with electromechanical or inductive micro switches on a manual VKD valve to remotely signal the valve position (open-closed). The kit can be assembled on the valve even if already installed on the system.

d	DN	B	B ₁	C	C ₁	Protection rate	Code. electromechanical	Code inductive	Code Namur
75	65	266	87	150	80	IP67	FKMS1M	FKMS1I	FKMS1N
90	80	279	105	150	80	IP67	FKMS1M	FKMS1I	FKMS1N
110	100	297	129	150	80	IP67	FKMS1M	FKMS1I	FKMS1N

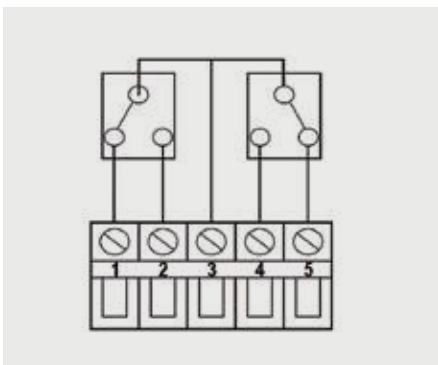

Electromechanical

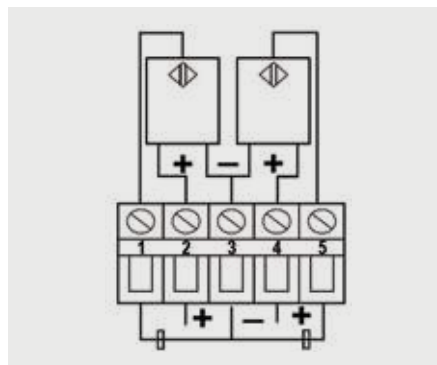

Inductive

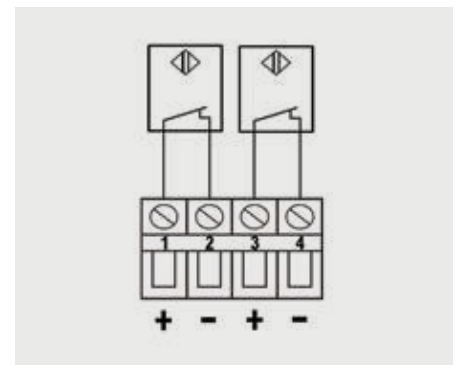

Namur*

* To be used with an amplifier

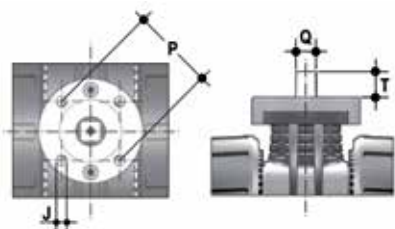

ACTUATOR MOUNTING FLANGE

The valve can be equipped with pneumatic or electric standard actuators and handwheel reduces for heavy-duty operations, using the PP-GR module reproducing the drilling pattern foreseen by ISO 5211 F07.

d	DN	P x J	T	Q
75	65	F07 x 9	16	14
90	80	F07 x 9	16	14
110	100	F07 x 9	19	17

FASTENING AND SUPPORTING



All valves, whether manual or actuated, must be adequately supported in many applications.

The VKD DN 65÷100 valve series is therefore provided with an integrated bracket that permits direct anchoring on the valve body without the need of other components.

Using standard threaded nuts (not included) made of stainless steel, you can anchor the valve on 4 fastening points.

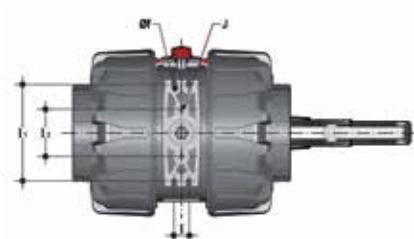

d	DN	J	f	l	l ₁	l ₂
75	65	M6	6.3	17.4	90	51.8
90	80	M6	8.4	21.2	112.6	63
110	100	M8	8.4	21.2	137	67

CUSTOMISATION

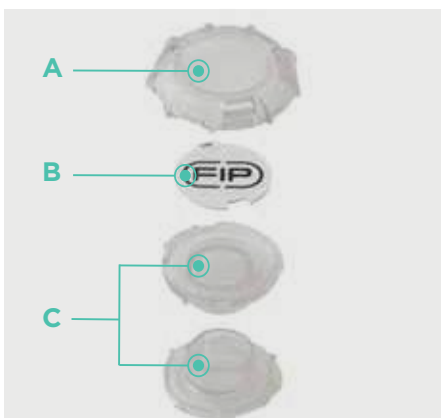

The VKD DN 65÷100 valve is equipped with the customisable Labelling System.

This system lets you create special labels to insert in the handle. This makes it extremely easy to apply company logos, identification serial numbers or service indications such as, for example, the valve function in the system, the transported fluid, but also specific information for customer service, such as the customer name or installation date or location on the valves.

The specific LCE module is a standard supply and is made up of a rigid transparent water-resistant PVC plug (A-C) and white tag holder (B) made of the same material, one side of which bears the FIP logo.

The holder, inserted in the plug, can be removed and, once overturned, used for customisation by applying labels printed with the software supplied with the LSE set.

Proceed as follows to apply the label on the valve:

- 1) Remove the upper part of the transparent plug (A) rotating it counter-clockwise as indicated by the "Open" label on the plug and remove it.
- 2) Extract the tag holder from its housing on the lower part of the plug (C)
- 3) Apply the adhesive label on the tag holder (B) to align the profiles matching the tab position.
- 4) Reinsert the tag holder in its housing at the bottom of the plug
- 5) Reposition the top of the plug in the housing rotating it clockwise; this way the label is protected against the elements.

COMPONENTS

EXPLODED VIEW

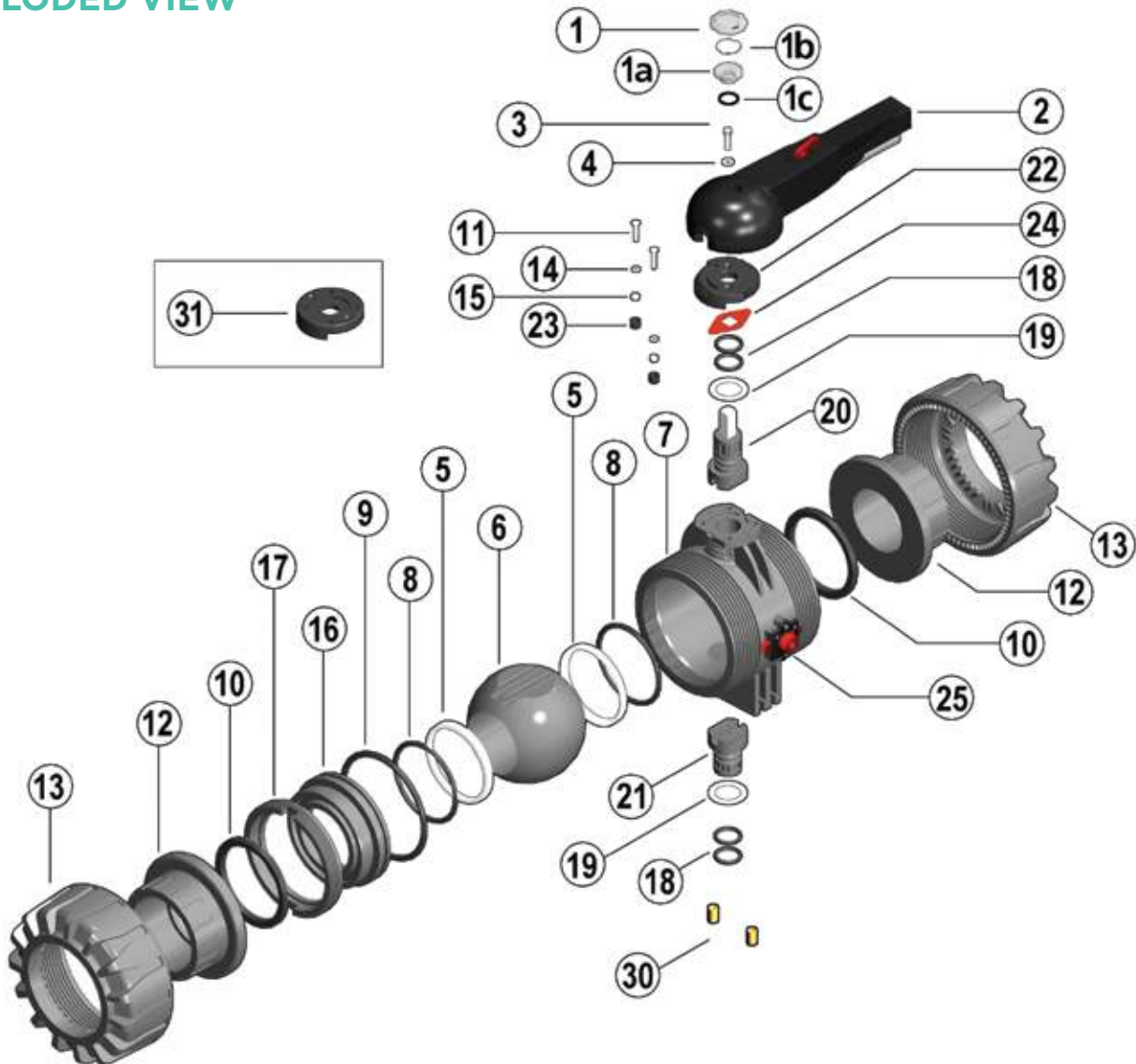

1-1a · Transparent protection plug (PVC - 1)

1b · Tag holder (PVC - 1)

1c · O-Ring (NBR - 1)

2 · Handle (HIPVC - 1)

3 · Screw (STAINLESS steel - 1)

4 · Washer (STAINLESS steel - 1)

5 · Ball seat (PTFE - 2)*

6 · Ball (PVC-U - 1)

7 · Body (PVC-U - 1)

8 · Ball seat O-ring (EPDM-FPM - 2)*

9 · Radial seal O-Ring (EPDM- FPM - 1)*

10 · Socket seal O-Ring (EPDM-FPM - 2)*

11 · Screw (STAINLESS steel - 2)

12 · End connector (PVC-U - 2)

13 · Union nut (PVC-U - 2)

14 · Washer (STAINLESS steel - 2)

15 · Nut (STAINLESS steel - 2)

16 · Ball seat carrier (PVC-U - 1)

17 · Threaded ring (PVC-U - 1)

18 · Stems O-Ring (EPDM-FPM - 4)

19 · Anti-friction disk (PTFE - 2)*

20 · Upper stem (PVC/Stainless steel- 1)

21 · Lower stem (PVC-U - 1)

22 · Plate (PP-GR - 1)

23 · Protection plug (PE - 2)

24 · Position indicator (PA - 1)

25 · DUAL BLOCK® (PP-GR + various- 1)

30 · Threaded inserts (Brass - 2)**

31 · Actuation plate (PP-GR - 1)**

* Spare parts

** Accessories

The component material and quantity supplied are indicated in the parentheses.

DISMOUNTING

- 1) Isolate the valve from the line (release the pressure and empty the pipeline).
- 2) Release the union nuts by rotating the button (25) to the left, pointing the arrow on the open lock (fig. 1).
- 3) Unscrew the union nuts (13) and extract the body (7) (fig. 2).
- 4) Before dismounting, hold the valve in a vertical position and open it 45° to drain any liquid that might remain.
- 5) Open the valve.
- 6) Remove the protection plug on the handle (2) and unscrew the screw (3) with the washer (4).
- 7) Remove the handle (2).
- 8) Remove the screws (11) and plate (22) from the body (7).
- 9) Insert the two supplied wrench protrusions in the corresponding apertures on the threaded ring (17), extracting it by rotating counter-clockwise with the ball seat carrier (16) (fig. 3).
- 10) Press on the ball (6), being careful not to scratch it, and remove it from the body.
- 11) Press the upper stem (20) inwards and extract it from the body and remove the lower stem (21). Remove the anti-friction disks (19).
- 12) Remove the O-Ring (8, 9, 10, 18) and PTFE ball seats (5) extracting them from their housings, as illustrated in the exploded view.

ASSEMBLY

- 1) All the O-rings (8, 9, 10, 18) must be inserted in their grooves as shown in the exploded view.
- 2) Place the anti-friction disks (19) on the stems (20-21) and insert the stems in their housings in the body.
- 3) Place the PTFE ball seats (5) in the housings in the valve body (7) and in the carrier (16).
- 4) Insert the ball (6) rotating it to the closed position.
- 5) Insert the carrier with threaded ring (17) into the body and tighten up in the clockwise direction using the supplied tool, to limit stop.
- 6) Position the plate (22) with rack on the body, and screw in the screws (11) washers (14) and nuts (15).
- 7) The handle (2) with protection plug (1, 1a, 1b, 1c) should be placed on the stem (20) (fig. 4).
- 8) Screw in the screw (3) with the washer (4) and position the protection plug (1, 1a, 1b, 1c).
- 9) Insert the valve between the end connectors (12) and tighten the union nuts (13), making sure that the socket seal O-rings (10) do not exit their seats.
- 10) Release the union nuts by rotating the button (25) to the right, pointing the arrow on the closed lock (fig. 1).



Note: during assembly operations, it is advisable to lubricate the rubber seals. Mineral oils are not recommended for this task as they react aggressively with EPDM rubber.

INSTALLATION

Before proceeding with installation, please follow these instructions carefully:

- 1) Check that the pipes to be connected to the valve are aligned in order to avoid mechanical stress on the threaded joints.
- 2) Make sure the DUAL BLOCK® union nut lock system (25) is in the FREE position.
- 3) Unscrew the union nuts (13) and insert them on the pipe segments.
- 4) Solvent weld or screw the end connectors (12) onto the pipe ends.
- 5) Position the valve body between the end connectors and fully tighten the union nuts (13) clockwise with an appropriate wrench.
- 6) Lock the union nuts rotating the button (25) clockwise (see paragraph "union nut lock").
- 7) If necessary, support the piping with FIP pipe clips or by means of the carrier built into the valve itself (see paragraph "fastening and supporting").

Adjust the ball seat carriers using the supplied tool (fig. 3).

The seals can be installed later with the valve installed on the pipe by simply tightening the union nuts. This "micro adjustment", only possible with FIP valves thanks to the patented "Seat stop system", allows the seal to be recovered where PTFE ball seats are worn due to a high number of operations.

Fig. 1



Fig. 2



Fig. 3



Fig. 4



UNION NUT LOCK

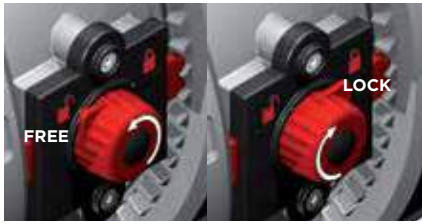

Rotate the button to the left, pointing the arrow on the open lock to unlock DUAL BLOCK®: the valve union nuts are free to rotate clockwise and counter-clockwise. Rotate the button to the right, pointing the arrow on the closed lock to lock DUAL BLOCK®: the valve union nuts are blocked in the desired position.

HANDLE LOCK



Thanks to the multifunctional handle and the red manoeuvre button on the lever, you can perform a 0°-90° operation and a graduated operation by means of the 10 intermediate positions and a stop lock: the handle can be locked in each of the 10 positions by simply pressing the Free-lock button. A lock can also be installed on the handle to protect the system against tampering.

The valve is two-way and can be installed in any position. It can also be installed at end line or tank.

WARNINGS

- If volatile liquid such as Hydrogen Peroxide (H₂O₂) or Sodium Hypochlorite (NaClO) are used, for safety reasons we recommend you contact the service centre. These liquids, upon vaporising, could create hazardous over pressures in the area between the body and ball.
- Always avoid sudden closing operations and protect the valve from accidental operations.



Aliaxis
UTILITIES & INDUSTRY

FIP - Formatura Iniezione Polimeri

Loc. Pian di Parata, 16015 Casella Genova Italy

Tel. +39 010 96211

Fax +39 010 9621.209

info.fip@aliaxis.com

www.fipnet.com



Code LEVAMAV